

OPTIONAL RESERVOIR

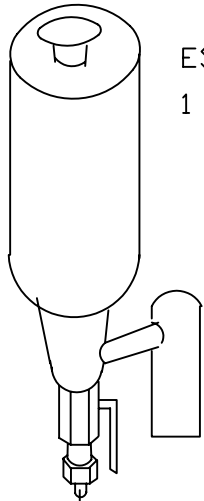

ES-374-RQ11
1 QT. RESERVOIR

INK LINE
1/4" O. D.
PLASTIC TUBING

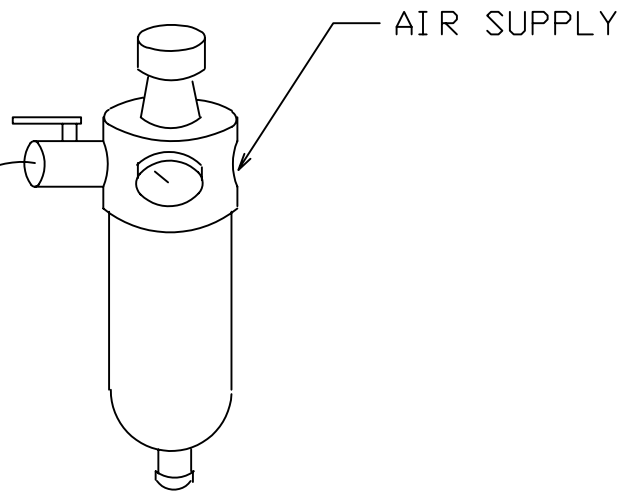

ES-375-RC3
AIR REGULATOR
MOISTURE CONDENSER

AIR LINE
1/4" O. D.
PLASTIC TUBING

ES-374-R27
3 OZ. RESERVOIR

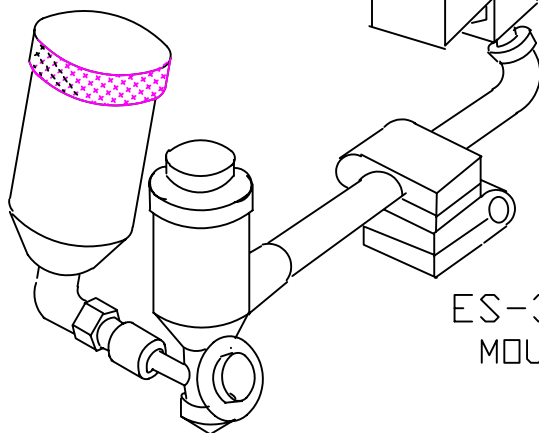

ES-370-ATO
SPRAY GUN

ES-376-VE3
SOL. VALVE
120 / 60 VAC OR 24 VDC

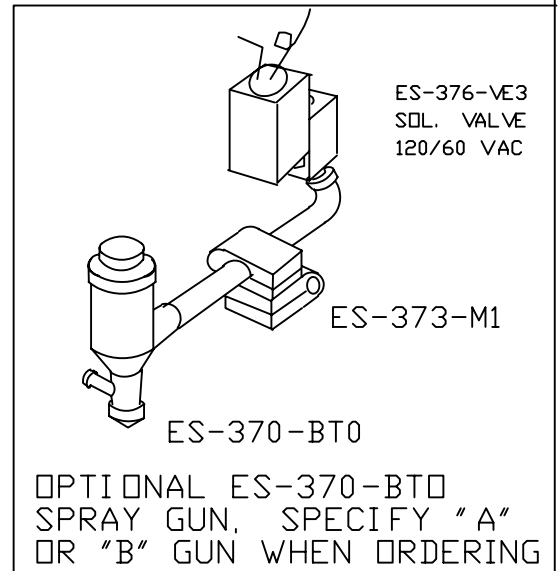

ES-370-BT0
OPTIONAL ES-370-BT0
SPRAY GUN, SPECIFY "A"
OR "B" GUN WHEN ORDERING

CARCO INC
10333 SHOEMAKER
DETROIT MICH. 48213
313-925-9000

GRAVITY FEED SPRAY SYS.

DATE

6-23-05

ES-800-(A)(B)G

ES-370-AKT-0 TRACING TEMPLET

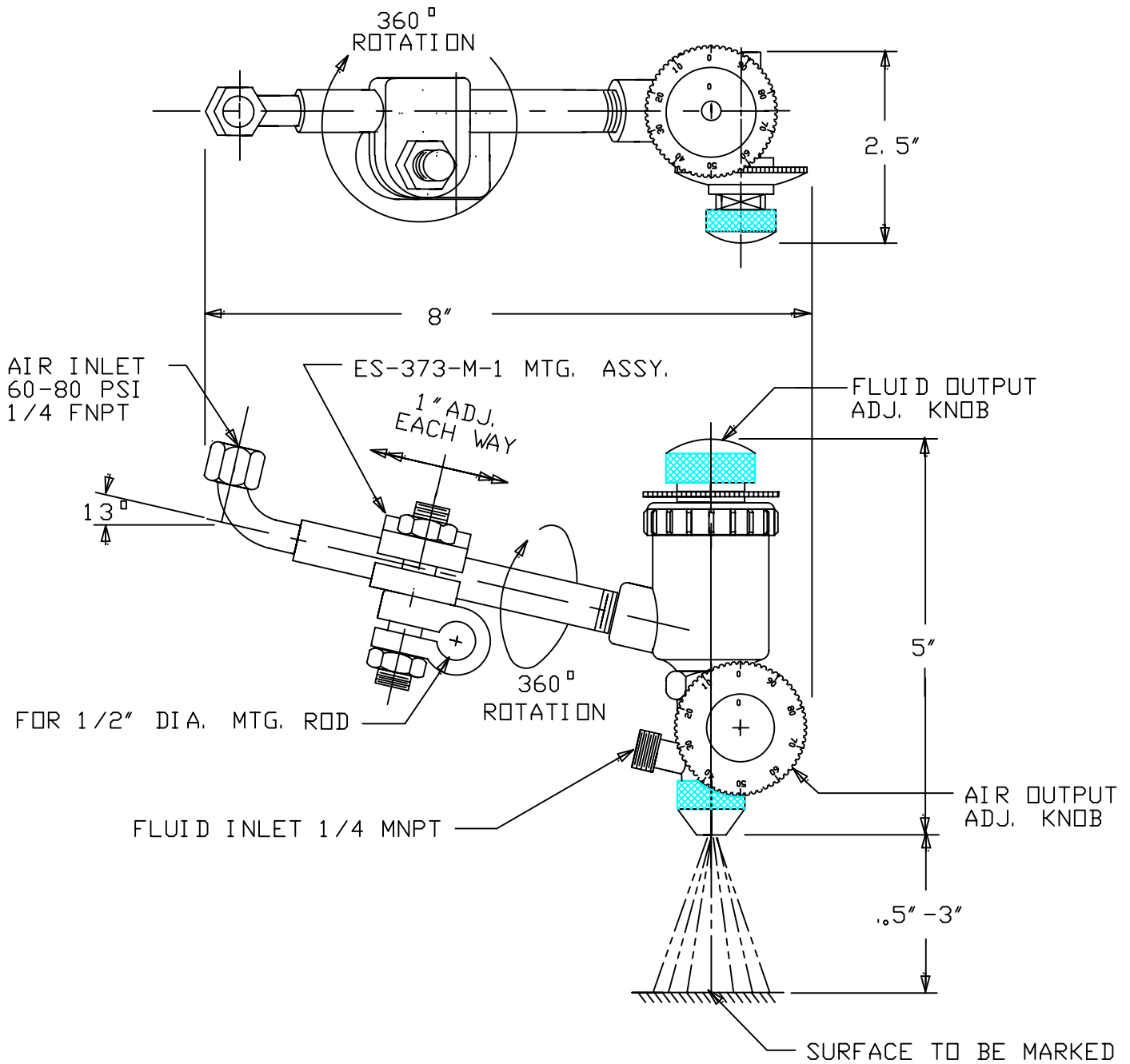

CARCO INC, 313-925-9000
DETROIT MICH. 48213

MARKING DEVICES and SPECIAL INKS

TRACING TEMPLET

DRAWN
BY M. E.
CHK' D

DATE
6-23-05
SCALE
1/2

ES-370-AKT-0

ES-370-BKT-0 TRACING TEMPLET

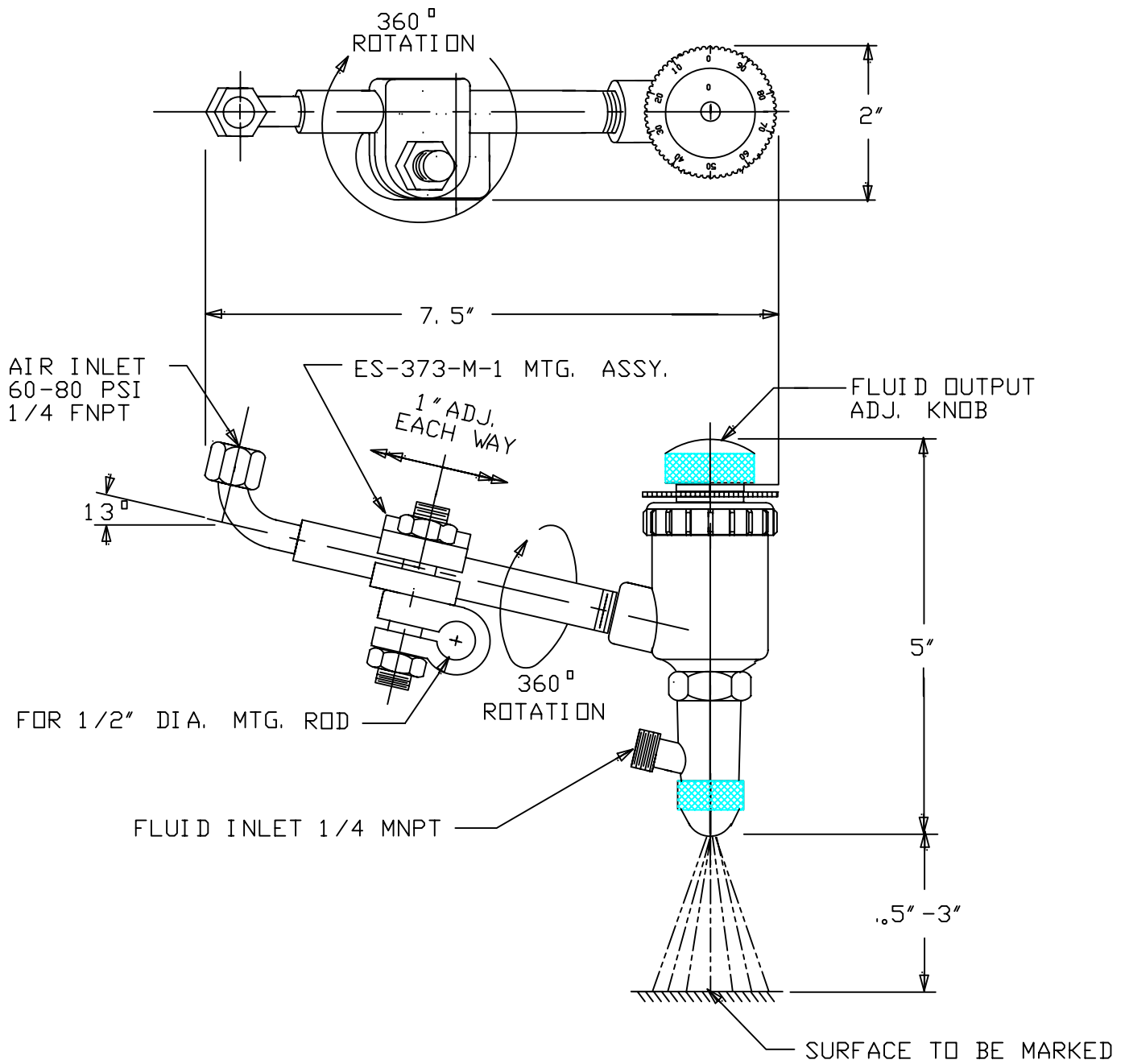

CARCO INC., 313-925-9000		
DETROIT MICH. 48213		
MARKING DEVICES and SPECIAL INKS		
TRACING TEMPLET		
DRAWN BY M. E.	DATE 6-23-05	ES-370-BKT-0
CHK' D	SCALE 1/2	

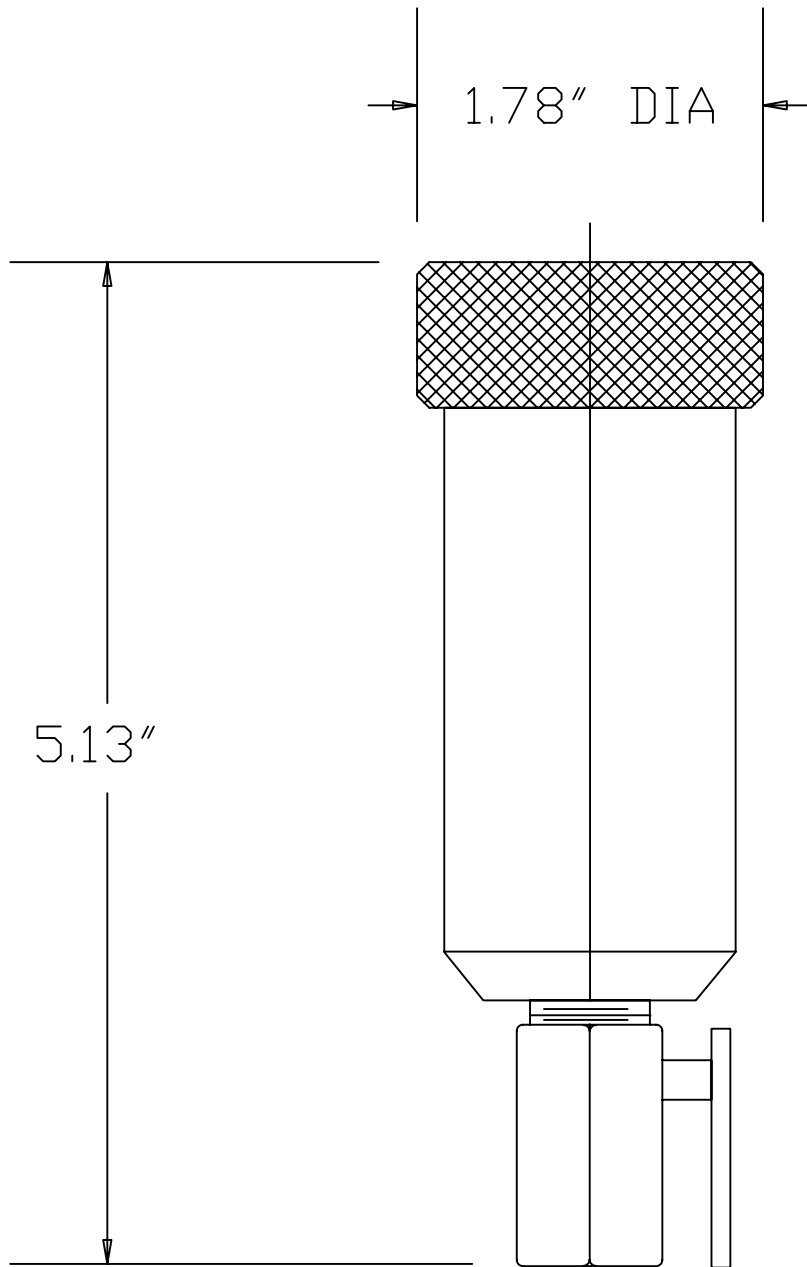

MATERIAL
 NYLON

CAPACITY
 2oz. FLUID

TRACING
TEMPLATE

1/4" NPT
 SHUTOFF VALVE

		313-925-9000
CARCO INC.		
10333 SHOEMAKER DETROIT MICH. 48213		
MARKING DEVICES and SPECIAL INKS		
2oz. RESERVOIR W/SHUTOFF VALVE		
DRAWN BY AD	DATE 12/02/05	ES-374-R27
CHK'D	SCALE FULL	

ES-374-RQ1 1

NOTE:

COVER RETAINING
CHAIN NOT SHOWN

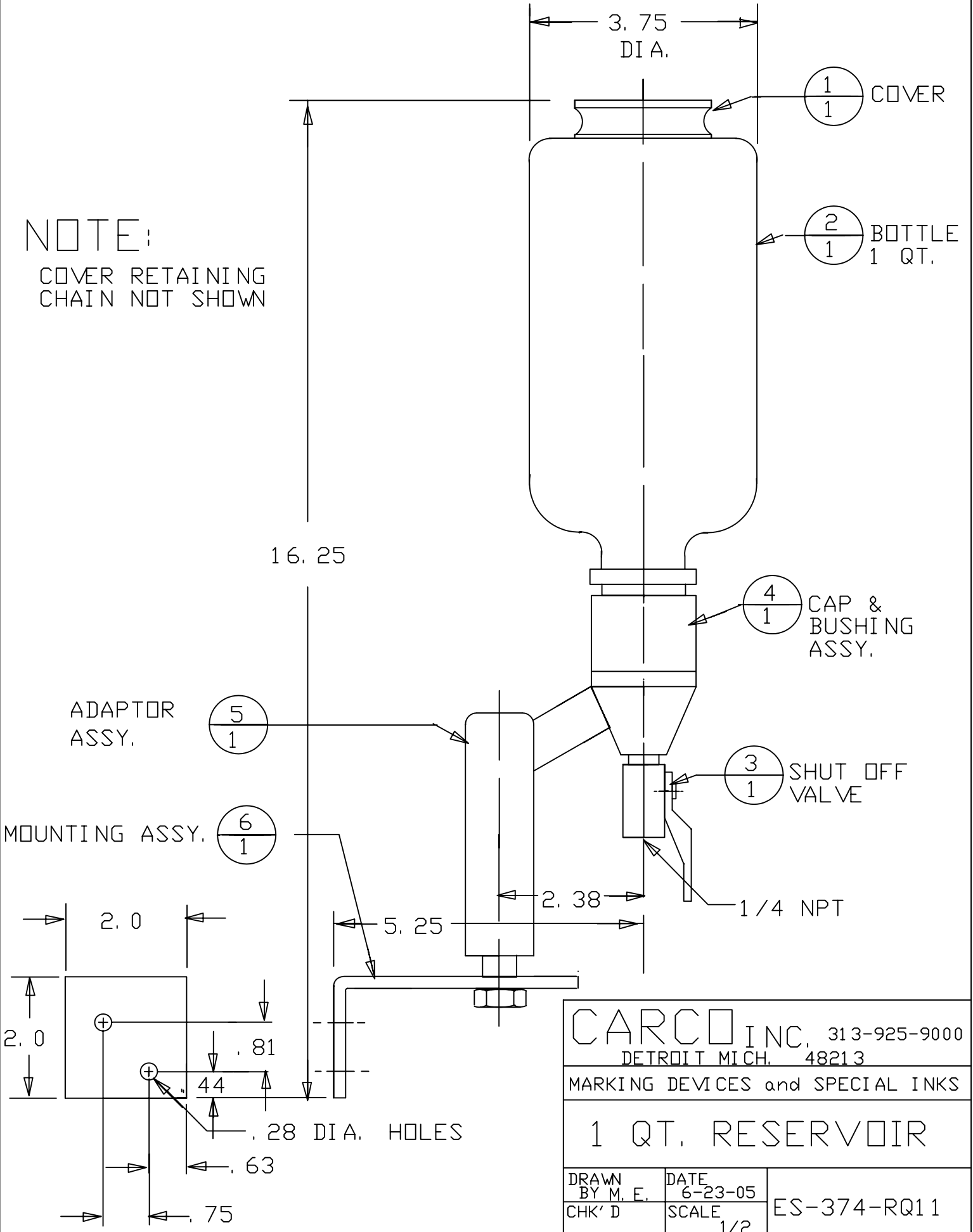

CARCO INC., 313-925-9000
DETROIT MICH. 48213

MARKING DEVICES and SPECIAL INKS

1 QT. RESERVOIR

DRAWN BY M. E.	DATE 6-23-05	ES-374-RQ1 1
CHK'D	SCALE 1/2	

CARCO ES-370 AKT Spray Gun

The ES-370 AKT Automatic Spray Gun is a production spray gun designed to apply a wide range of marking fluids, including Carco pigmented and dye type marking fluids.

CONNECTIONS:

- 1) Connect a hose from the air supply to the air inlet fitting. (1/4" S.P.T. 60-80 psi)
- 2) Connect the fluid supply to the fluid inlet. (1/4" S.P.T.) If a remote, gravity feed reservoir is used, be sure to mount the reservoir at least 12" above the spray gun.
- 3) Tighten all hose connections securely.

OPERATIONS:

This spray gun operates by mixing air and fluid, creating an atomized mist emitted from the tip. The basic size and intensity of the spray mark is determined by the following:

- a) Type of marking fluid, viscosity and color.
- b) Distance from the part being marked.
- c) Duration of the spray
- d) Fluid / Air ratio

Establishing the proper fluid /air is best done by totally closing both the air adjusting knob and the fluid adjusting knob. By slowly opening both valves, the desired pattern can be established. Once determined, note the dial settings for future reference.

CLEANING:

Basic cleaning of the spray gun can be accomplished by flushing the gun with clean solvent. Use the solvent that is specific to the marking fluid used in the gun. Do not use caustic or alkaline solutions for cleaning. Do not leave the entire gun immersed in the solvent. Dirty and clogged air caps and tips should be cleaned by removing and soaking in solvent. Use plant air to blow them clean after removal from the solvent.

TROUBLESHOOTING AND DISASSEMBLY

Sputter spray can be caused by clogged marking fluid or a cracked tip. Try opening the air and fluid knobs all the way to maximize the output. If this does not improve performance, the air cap and tip should be checked. **IMPORTANT:** The ES-370 spray gun has an internal spring that can damage the tip during disassembly. To prevent cracking the tip, remove the cylinder cap assembly before removing the air cap nut and tip. Loosen the piston assembly by pulling the needle up about one half inch. Before re-installing the cylinder cap assembly, turn the fluid adjustment knob counter-clockwise until it stops. This will prevent tip damage, and ease installation.

Air flowing back into the reservoir indicates the needle packing is worn and should be replaced.

At this point it is recommended that an **ES-370 Repair Kit**, consisting of a packing assembly, needle, leather cup, air cap and tip be used to rebuild the spray gun.

